

Alliant Engineering Inc Minneapolis, MN 55415

17th Ave N/CSAH-73 at Minnetonka Mills Rd
Ref.Pt.:
Alliant Engineering Inc
TURN MOVEMENT COUNT

File Name : 14_CR 73 at Minnetonka Mills(5th St)_011311
Site Code : 00000014
Start Date : 1/13/2011
Page No : 1

Groups Printed- Unshifted - Bank 1

Start Time	17th Ave N / CSAH-73 Southbound				5th St N Westbound				17th Ave N / CSAH-73 Northbound				Minnetonka Mills Rd Eastbound				Int. Total
	Left	Thru	Right	Peds	Left	Thru	Right	Peds	Left	Thru	Right	Peds	Left	Thru	Right	Peds	
06:00	4	12	0	0	9	0	0	0	3	14	4	0	1	1	1	0	49
06:15	3	16	2	0	7	0	3	0	1	16	3	0	3	3	7	0	64
06:30	4	37	3	0	4	1	6	0	5	34	8	0	10	3	4	0	119
06:45	7	32	9	0	15	2	7	0	15	50	3	0	10	8	8	0	166
Total	18	97	14	0	35	3	16	0	24	114	18	0	24	15	20	0	398
07:00	7	47	9	0	12	2	7	0	13	59	8	0	11	5	6	0	186
07:15	14	71	9	0	20	1	11	0	11	135	9	0	14	4	9	0	308
07:30	20	75	11	0	29	6	15	0	13	89	6	0	14	9	14	0	301
07:45	13	110	14	0	20	3	14	0	28	57	8	0	7	11	6	0	291
Total	54	303	43	0	81	12	47	0	65	340	31	0	46	29	35	0	1086
08:00	13	50	13	0	25	2	9	1	17	75	10	0	6	6	9	0	236
08:15	9	49	9	0	15	4	15	0	17	53	9	0	8	8	15	1	212
08:30	17	64	6	0	23	5	17	0	18	44	15	0	16	16	16	0	257
08:45	23	63	9	0	49	10	34	0	30	42	9	0	9	16	11	0	305
Total	62	226	37	0	112	21	75	1	82	214	43	0	39	46	51	1	1010
09:00	12	49	8	0	24	8	11	1	24	47	8	1	11	6	24	0	234
09:15	9	31	11	0	20	3	12	0	22	43	11	1	11	6	17	0	197
*** BREAK ***																	
Total	21	80	19	0	44	11	23	1	46	90	19	2	22	12	41	0	431
*** BREAK ***																	
10:30	11	37	12	1	14	3	14	0	23	34	3	0	15	9	16	0	192
10:45	10	21	5	0	7	8	7	1	27	38	6	0	9	6	19	0	164
Total	21	58	17	1	21	11	21	1	50	72	9	0	24	15	35	0	356
11:00	17	42	8	1	23	3	10	0	22	54	4	0	8	7	23	0	222
11:15	15	43	12	0	27	4	11	0	36	41	4	0	15	3	17	0	228
11:30	8	54	8	0	14	6	10	0	23	44	14	0	21	3	16	0	221
11:45	8	40	11	0	11	4	7	0	33	51	8	0	15	6	24	0	218
Total	48	179	39	1	75	17	38	0	114	190	30	0	59	19	80	0	889
12:00	10	41	10	0	17	1	16	0	22	41	6	0	12	6	25	0	207
12:15	14	48	15	2	24	8	8	0	32	49	8	0	10	5	15	0	238
12:30	8	48	8	0	17	3	12	0	33	33	7	0	10	5	9	0	193
12:45	9	49	14	0	17	3	13	0	29	36	8	0	11	10	19	0	218
Total	41	186	47	2	75	15	49	0	116	159	29	0	43	26	68	0	856
13:00	7	52	11	0	15	4	6	0	35	46	10	0	12	3	16	0	217
13:15	7	78	14	2	17	5	9	1	37	86	8	0	20	3	17	0	304
*** BREAK ***																	
Total	14	130	25	2	32	9	15	1	72	132	18	0	32	6	33	0	521
*** BREAK ***																	
14:30	6	43	8	0	17	11	17	0	27	69	6	0	23	8	19	0	254
14:45	11	111	18	1	19	18	11	0	39	88	4	0	16	6	13	0	355
Total	17	154	26	1	36	29	28	0	66	157	10	0	39	14	32	0	609
15:00	17	75	19	0	16	9	14	0	20	97	7	0	10	9	24	1	318
15:15	20	55	19	2	27	6	18	0	31	112	18	0	20	16	10	0	354
15:30	16	83	17	1	36	16	30	0	31	104	13	0	15	5	16	1	384
15:45	18	115	15	0	37	15	26	0	38	148	8	0	23	10	26	0	479
Total	71	328	70	3	116	46	88	0	120	461	46	0	68	40	76	2	1535

Alliant Engineering Inc Minneapolis, MN 55415

17th Ave N/CSAH-73 at Minnetonka Mills Rd
Ref.Pt.:
Alliant Engineering Inc
TURN MOVEMENT COUNT

File Name : 14_CR 73 at Minnetonka Mills(5th St)_011311
Site Code : 00000014
Start Date : 1/13/2011
Page No : 2

Groups Printed- Unshifted - Bank 1

Start Time	17th Ave N / CSAH-73 Southbound				5th St N Westbound				17th Ave N / CSAH-73 Northbound				Minnetonka Mills Rd Eastbound				Int. Total
	Left	Thru	Right	Peds	Left	Thru	Right	Peds	Left	Thru	Right	Peds	Left	Thru	Right	Peds	
16:00	10	84	21	0	26	8	25	0	30	106	13	0	28	9	26	0	386
16:15	17	88	19	1	20	11	27	0	30	169	15	2	17	6	12	0	434
16:30	10	120	23	0	28	18	24	2	32	171	14	0	26	15	18	0	501
16:45	13	112	17	0	24	8	26	0	28	202	6	1	21	5	25	0	488
Total	50	404	80	1	98	45	102	2	120	648	48	3	92	35	81	0	1809
17:00	20	89	15	0	23	13	15	0	41	200	4	0	24	10	35	0	489
17:15	17	134	20	0	18	29	26	0	31	196	5	0	31	17	24	0	548
17:30	21	88	27	1	24	18	31	0	42	194	7	0	40	17	18	0	528
17:45	11	110	12	0	29	19	24	0	32	188	8	0	33	18	23	0	507
Total	69	421	74	1	94	79	96	0	146	778	24	0	128	62	100	0	2072
Grand Total	486	2566	491	12	819	298	598	6	1021	3355	325	5	616	319	652	3	11572
Apprch %	13.7	72.2	13.8	0.3	47.6	17.3	34.7	0.3	21.7	71.3	6.9	0.1	38.7	20.1	41	0.2	
Total %	4.2	22.2	4.2	0.1	7.1	2.6	5.2	0.1	8.8	29	2.8	0	5.3	2.8	5.6	0	
Unshifted	474	2536	485	12	801	292	577	6	1001	3309	314	5	605	309	636	3	11365
% Unshifted	97.5	98.8	98.8	100	97.8	98	96.5	100	98	98.6	96.6	100	98.2	96.9	97.5	100	98.2
Bank 1	12	30	6	0	18	6	21	0	20	46	11	0	11	10	16	0	207
% Bank 1	2.5	1.2	1.2	0	2.2	2	3.5	0	2	1.4	3.4	0	1.8	3.1	2.5	0	1.8

Alliant Engineering Inc Minneapolis, MN 55415

17th Ave N/CSAH-73 at Minnetonka Mills Rd
Ref.Pt.:
Alliant Engineering Inc
TURN MOVEMENT COUNT

File Name : 14_CR 73 at Minnetonka Mills(5th St)_011311
Site Code : 0000014
Start Date : 1/13/2011
Page No : 3

Start Time	17th Ave N / CSAH-73 Southbound					5th St N Westbound					17th Ave N / CSAH-73 Northbound					Minnetonka Mills Rd Eastbound					Int. Total
	Left	Thru	Right	Peds	App. Total	Left	Thru	Right	Peds	App. Total	Left	Thru	Right	Peds	App. Total	Left	Thru	Right	Peds	App. Total	
Peak Hour Analysis From 06:00 to 09:15 - Peak 1 of 1																					
Peak Hour for Entire Intersection Begins at 07:15																					
07:15	14	71	9	0	94	20	1	11	0	32	11	135	9	0	155	14	4	9	0	27	308
07:30	20	75	11	0	106	29	6	15	0	50	13	89	6	0	108	14	9	14	0	37	301
07:45	13	110	14	0	137	20	3	14	0	37	28	57	8	0	93	7	11	6	0	24	291
08:00	13	50	13	0	76	25	2	9	1	37	17	75	10	0	102	6	6	9	0	21	236
Total Volume	60	306	47	0	413	94	12	49	1	156	69	356	33	0	458	41	30	38	0	109	1136
% App. Total	14.5	74.1	11.4	0		60.3	7.7	31.4	0.6		15.1	77.7	7.2	0		37.6	27.5	34.9	0		
PHF	.750	.695	.839	.000	.754	.810	.500	.817	.250	.780	.616	.659	.825	.000	.739	.732	.682	.679	.000	.736	.922

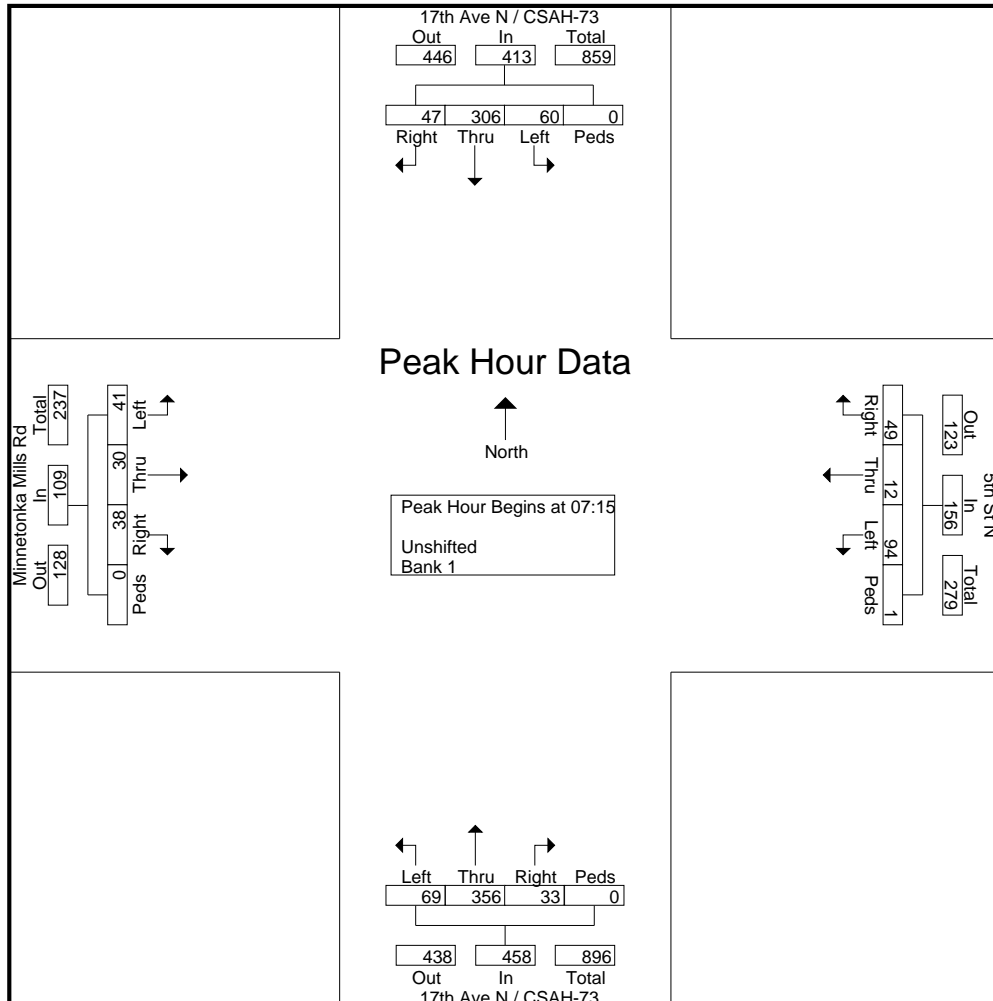

Alliant Engineering Inc Minneapolis, MN 55415

17th Ave N/CSAH-73 at Minnetonka Mills Rd
Ref.Pt.:
Alliant Engineering Inc
TURN MOVEMENT COUNT

File Name : 14_CR 73 at Minnetonka Mills(5th St)_011311
Site Code : 0000014
Start Date : 1/13/2011
Page No : 4

Start Time	17th Ave N / CSAH-73 Southbound					5th St N Westbound					17th Ave N / CSAH-73 Northbound					Minnetonka Mills Rd Eastbound					Int. Total
	Left	Thru	Right	Peds	App. Total	Left	Thru	Right	Peds	App. Total	Left	Thru	Right	Peds	App. Total	Left	Thru	Right	Peds	App. Total	
Peak Hour Analysis From 14:30 to 17:45 - Peak 1 of 1																					
Peak Hour for Entire Intersection Begins at 17:00																					
17:00	20	89	15	0	124	23	13	15	0	51	41	200	4	0	245	24	10	35	0	69	489
17:15	17	134	20	0	171	18	29	26	0	73	31	196	5	0	232	31	17	24	0	72	548
17:30	21	88	27	1	137	24	18	31	0	73	42	194	7	0	243	40	17	18	0	75	528
17:45	11	110	12	0	133	29	19	24	0	72	32	188	8	0	228	33	18	23	0	74	507
Total Volume	69	421	74	1	565	94	79	96	0	269	146	778	24	0	948	128	62	100	0	290	2072
% App. Total	12.2	74.5	13.1	0.2		34.9	29.4	35.7	0		15.4	82.1	2.5	0		44.1	21.4	34.5	0		
PHF	.821	.785	.685	.250	.826	.810	.681	.774	.000	.921	.869	.973	.750	.000	.967	.800	.861	.714	.000	.967	.945

